

ASECAP DAYS



MILANO 2024

FREETO 
Sostenibilità. Innovazione. Mobilità

ORGANIZED BY



HOSTED BY



ASECAP DAYS



MILANO 2024

Free to X: E-Mobility Solutions

ORGANIZED BY



HOSTED BY



Free To X is 2nd largest HPC network in Italy

104 STATIONS AND 610 CPs INSTALLED AS OF TODAY

Fast deployment in less than 2 years

Free To X became the 2nd largest network in the HPC market in Italy, launching 104 stations in 12 regions and pioneering new technologies on its charging infrastructure (e.g., Plug&Charge, 400 KW, etc.)

FOCUS ON HYPER FAST CHARGING

Wide range of solutions fully accessible to all EV owners with a specific focus on HPC

Entire spectrum of electric charging technology solutions available by covering the needs of all types of users and vehicles, with a main focus on high-power solutions

WELL DISTRIBUTED HIGH-TRAFFIC LOCATIONS

Characterized by best-in-class utilization rate

Intensive scouting activity looking for prime partners and locations already proven by initial expansion outside the ASPI network (SEA and Catania airports tenders recently won)

FOCUS ON HIGH VALUE ADDED ACTIVITIES

Strong internal know-how

Operating model focusing on high value added activities whose distinctive factors are (i) the strong internal know-how in terms of EVCI operations, (ii) availability of flexible but turnkey solutions and (iii) the extensive track record in prompt and end-to-end projects' delivery

Impressive track record with 104 HPC stations deployed in less than 22 months

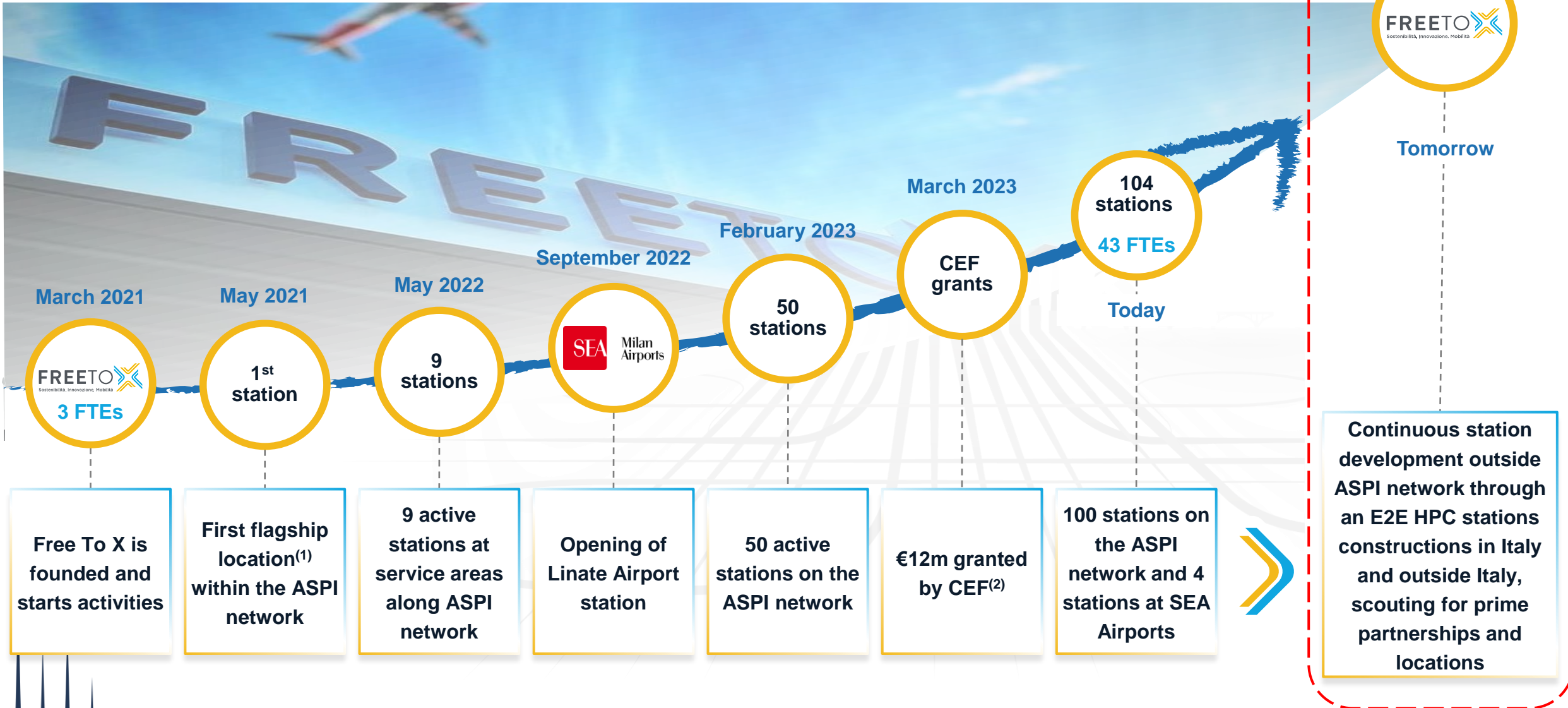



FREETO

Sostenibilità. Innovazione. Mobilità

Company founded in 2021 with headquarters in Rome and part of the **Group Motorways for Italy** (ASPI)

Travel and **mobility** concepts by focusing on **sustainability** and **innovation**

Offer based on **the installation and management of ultra-fast charging infrastructures** for electric vehicles



104
stations

installed in 2022-23



~600

charging points throughout the national territory



70%

focus on ultra-fast charging



400 kW

maximum charging power



100%

modularity and scalability



100%

renewable energies

Electric charging Free to X shelters

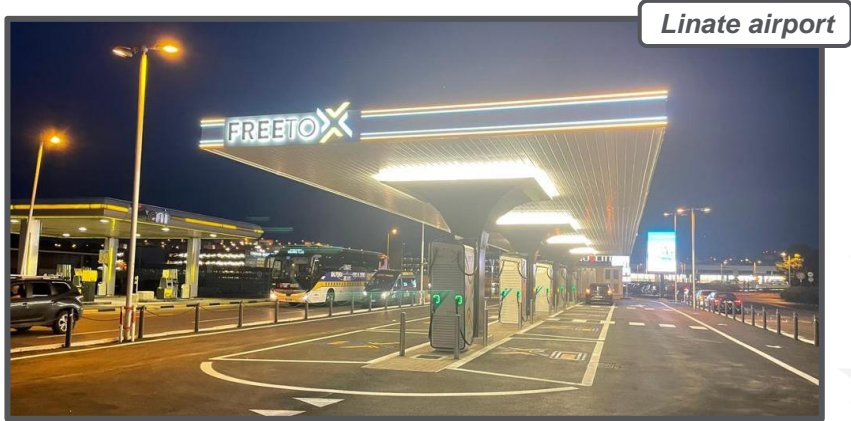

Linate airport



Esino West

Our HPC stations are **modular, scalable and high-performance**, enabling our partners to have a **cutting-edge charging experience** by providing the most advanced charging infrastructure, making us one of the leading suppliers in the evolving EV market.

The deployment plan 2024 (Q2-Q3):



+ FTX shelters catalogue development
+ development of new initiatives



Sillaro West

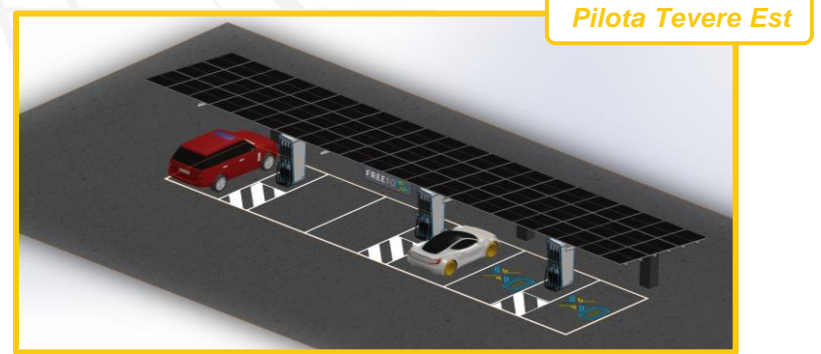

Installed 2 HPC 300kW plus 1 FC 64kW for every station, CCS2 CHAdeMO and Type2 standard covered

Standard configuration includes 2 high power chargers plus 1 multi-standard chargers in order to **fullfill all the standard in the EV market.**

Standard configuration





HPC 300kW



CCS 2 DC charging CCS 2 DC charging

FC 64kW

CHAdeMO DC charging

Type 2 AC charging (22kW)

FOCUS: Pilot Energy storage



The energy storage system was implanted in the Bevano Est charging station due to the low electrical power available from the distribution system operator (DSO).

The grid currently available, coming by the the DSO, is 80 Kw/H, which will be upgraded by the **Storage to a capacity of 300 Kw/H.** The station is ready to be operational but awaiting permission from the DSO.

Free To X operates as a neutral CPO



Free To X operates as a neutral CPO, making its charging network available to the vast majority of MSPs active on the Italian and European markets and applying the same economic conditions to all MSPs, both those with OCPI integration and those roaming.

MSP with peer-to-peer (P2P) integration



e-Roaming platform

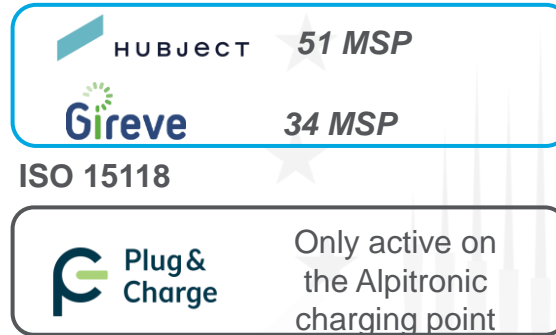

MSP with ongoing P2P integration



85 MSP

Main Mobility Service Provider:

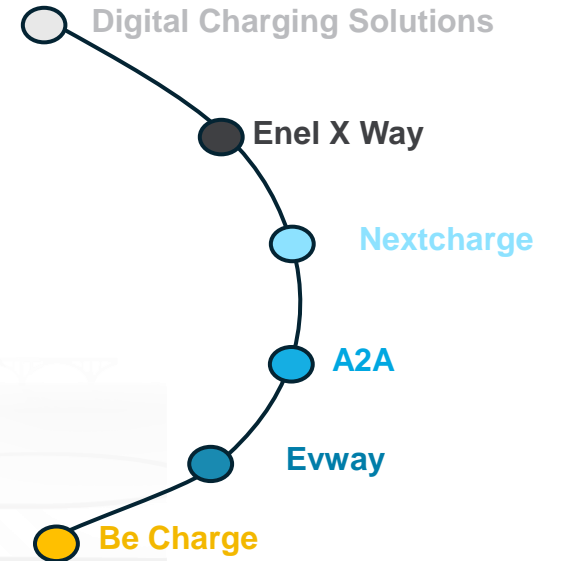

POS payment PILOT

Today the payment for top-up sessions is made with the apps of the eMSP operators or with the Equivalents of roaming operators.

First pilot from Q2'22 to Q3'23 on two stations with custom solution: **16% payment with POS.**



The integration of the POS payment on all charging stations starting from new ones Stations that will be put into operation in the coming months. We are thinking of a rollout of the POS solution on the network in Q4'24.

Off-highway expansion began with four charging stations on the airports of Milan Linate and Milan Malpensa

Initiative



In December 2021, Free To X was awarded the tender for the infrastructure of Milan airports with electric charging stations



The inauguration of the first superfast charging station took place at **Linate** on September 12, 2022, with a delivery time for the entire project of **less than 6 months**



Plan includes **100 percent certified green energy** and innovative **shelters** equipped with photovoltaic technology

Layout

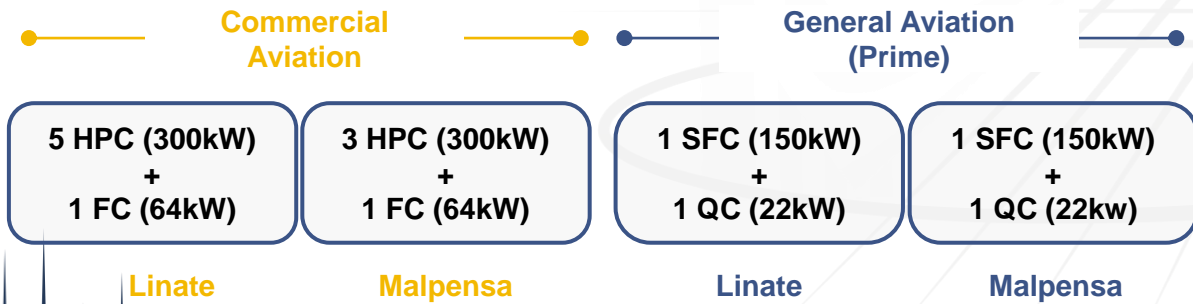

A mission-critical leader in Italy's fast-growing EV charging infrastructure market enabling the country's EV-transition

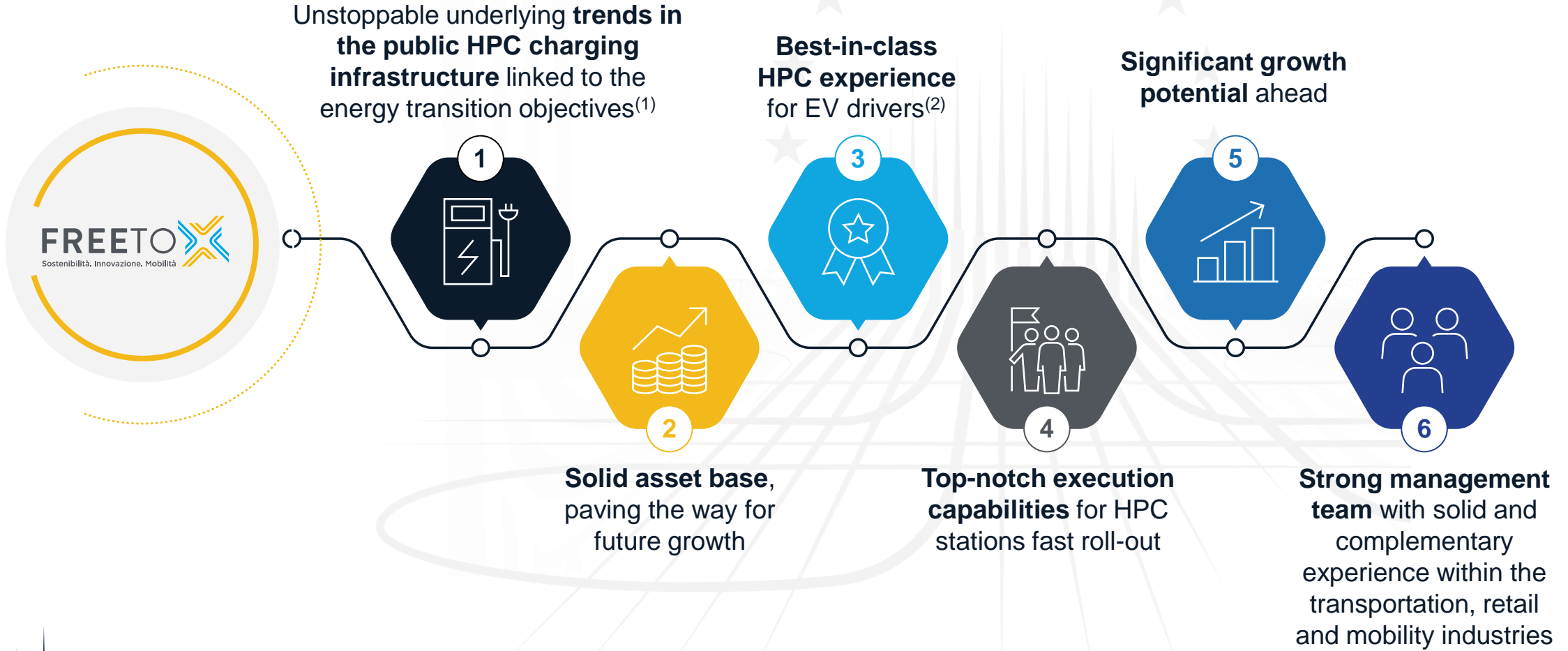

What Free To X does in the world of electric vehicle charging

Land owner



Owner/licensee of the area on which the charging infrastructure is located

Infrastructure owner



Owner of the **entire** charging **infrastructure**
Owner of the **connection** to the electricity grid and relations with the **DSO**

Charging Point Operator (CPO)



Manages and operates the **HW** (charging station) and **SW** (back-end platform) infrastructure
Manages the relationship with the **MSP** (**B2B**) to which it sells the service

e-Mobility Service Provider (MSP)



It sells charging services (and other ancillary products) to the end user
Management of B2C relationships with the customer base

Products offered & the company's vision of the future:

Technologies

Charging power

Charging speed

Ultra fast
(HPC ¹)



300-400
kW

15-20
minutes



- The company is committed to the continuous development of its high-power charging station network
- Leveraging our specialization by constructing end-to-end HPC stations technology and in our modular, scalable solutions, we are committed to becoming the leading provider of HPC stations across Europe
- This includes expanding beyond the ASPI network in Italy and into other countries along major routes
- The company is actively seeking partnerships and scouting for prime locations



1. High Power Charging (ie, ultra fast charging)

ASECAP DAYS



MILANO 2024

THANK YOU

GRAZIE

ANDREA MANFRON

andrea.manfron@freeto-x.it

+39 335 5635967



HOSTED BY



ORGANIZED BY

